

| | | | | | | | | | | | |
|---|--|--|---------|--|------------------------------------|--|----------------------|--|------------------|--|--------------|
| UNLESS OTHERWISE SPECIFIED: DIMENSIONS ARE IN MILLIMETERS SURFACE FINISH: TOLERANCES: LINEAR: ANGULAR: | | | FINISH: | | DEBURR AND BREAK SHARP EDGES | | DO NOT SCALE DRAWING | | REVISION | | |
| DRAWN | | | NAME | | SIGNATURE | | DATE | | TITLE: | | |
| CHK'D | | | | | | | | | | | |
| APPV'D | | | | | | | | | | | |
| MFG | | | | | | | | | | | |
| Q.A | | | | | | | MATERIAL: | | DWG NO. | | |
| | | | | | | | | | 1000 NEW SAMPASH | | |
| | | | | | | | WEIGHT: | | SCALE:1:20 | | SHEET 1 OF 2 |

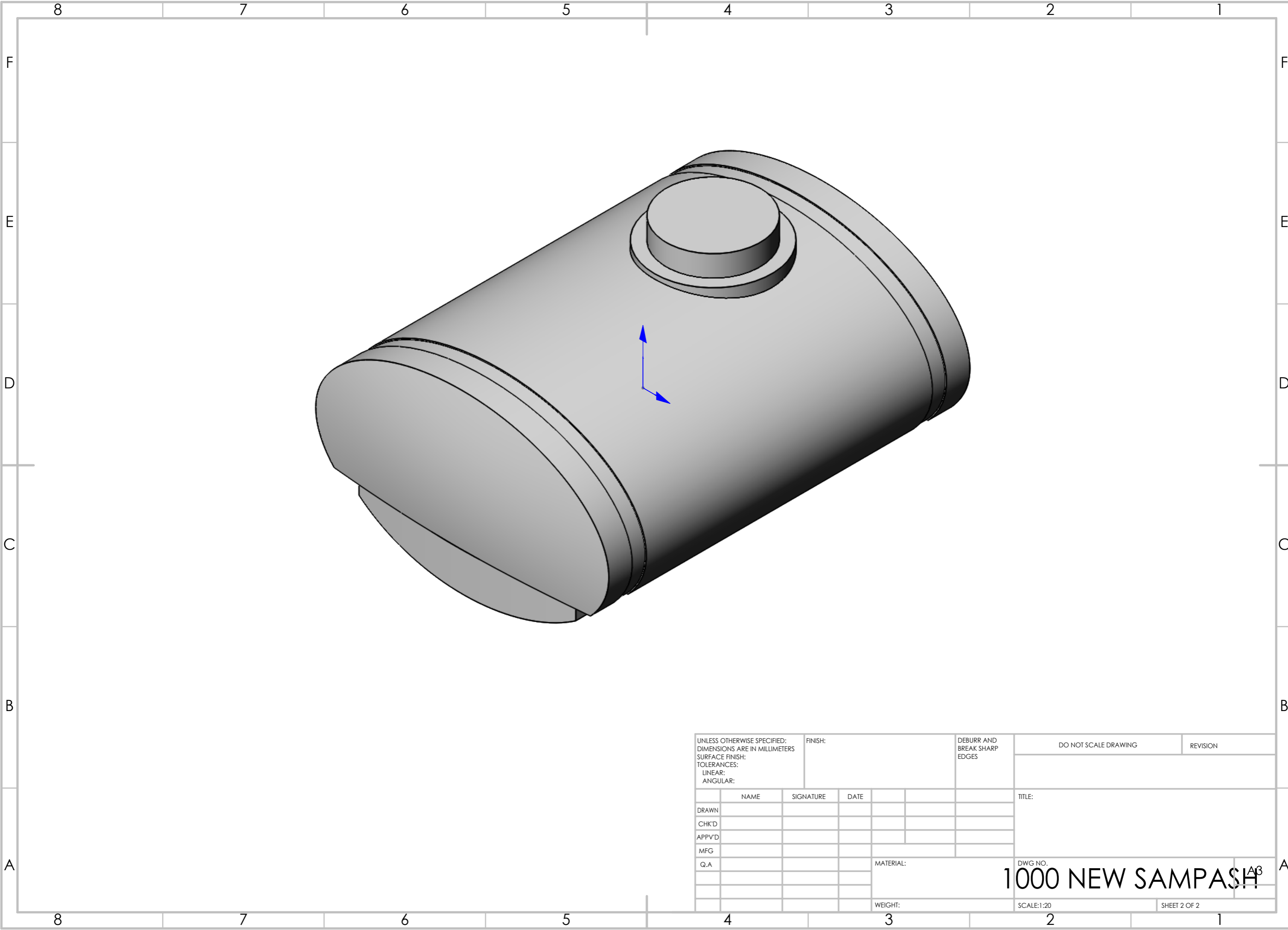

| | | | | | | | | | | | |
|--|------|-----------|------|---------|--|------------------------------------|--|----------------------|--|--------------|--|
| UNLESS OTHERWISE SPECIFIED: DIMENSIONS ARE IN MILLIMETERS | | | | FINISH: | | DEBURR AND BREAK SHARP EDGES | | DO NOT SCALE DRAWING | | REVISION | |
| SURFACE FINISH: | | | | | | | | | | | |
| TOLERANCES: | | | | | | | | | | | |
| LINEAR: | | | | | | | | | | | |
| ANGULAR: | | | | | | | | | | | |
| | NAME | SIGNATURE | DATE | | | | | TITLE: | | | |
| DRAWN | | | | | | | | | | | |
| CHK'D | | | | | | | | | | | |
| APPV'D | | | | | | | | | | | |
| MFG | | | | | | | | | | | |
| Q.A | | | | | | | | | | | |
| | | | | | | MATERIAL: | | DWG NO. | | A3 | |
| | | | | | | | | 1000 NEW SAMPASH | | | |
| | | | | | | WEIGHT: | | SCALE:1:20 | | SHEET 2 OF 2 | |